



Sharing high-tech ambitions

VDL Enabling Technologies Group

High Tech Mechatronics

Simon Bambach, 24 Maart 2011



**Established in 1900 as
Philips Machinefabrieken**



**1980: begin offering solutions
to external customers**



**From components to modules
and complete systems**



**2000: become Philips Enabling
Technologies Group**



**2006: become VDL Enabling
Technologies Group**



History customer relationships

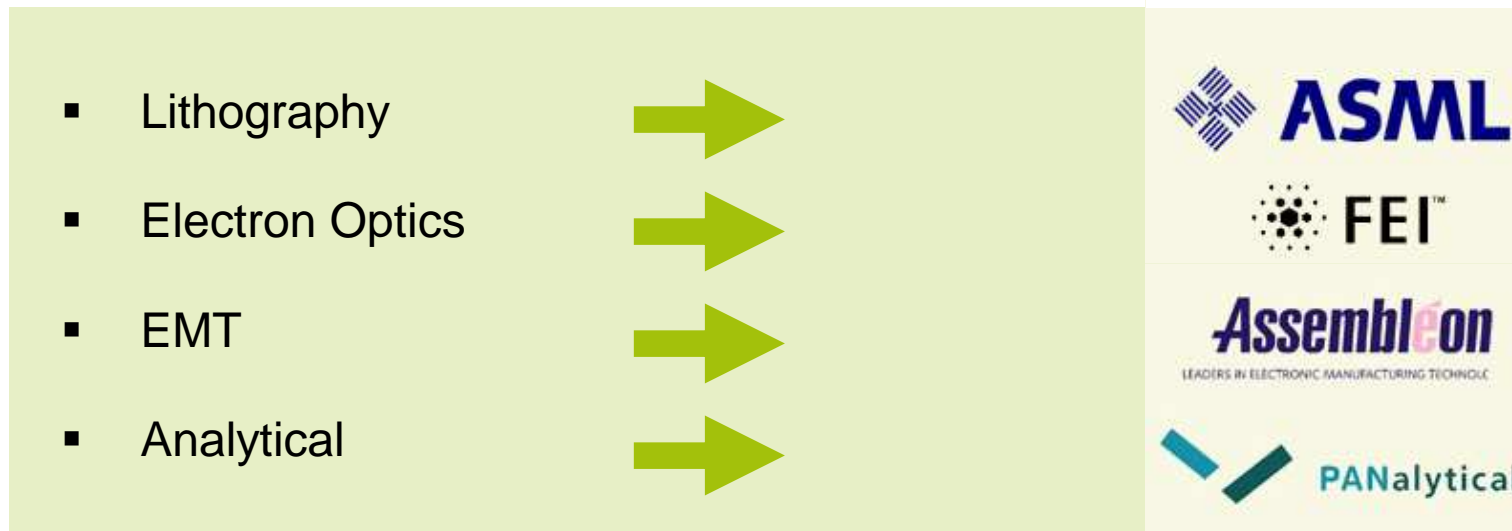

PHILIPS Science and Industrie



History

- VDL has acquired the 'Enabling Technologies Group' from Philips per Nov 6th, 2006.
- The establishment in **1953** of 'Metaalindustrie en Constructiewerkplaats P. van der Leegte' laid the basis for what today is the VDL Groep. Partly through targeted acquisition - initially in the supply sector and since the nineteen nineties in the finished products sector - the group now encompasses 78 subsidiaries, spread over 14 countries, and a workforce of 7,490.



VDL Group



sub contracting

- mechatronic systems
- module assembly
- part and sheet metal
- surface treatments
- plastic processing
- other specialities

bus group

- touringcars
- public transport bus
- mini and midi busses
- chassis modules
- second hand trade

finished products

- medical equipment
- process installations
- consumer products
- production automation
- various products



Consolidated turnover
(x € 1,000,000)

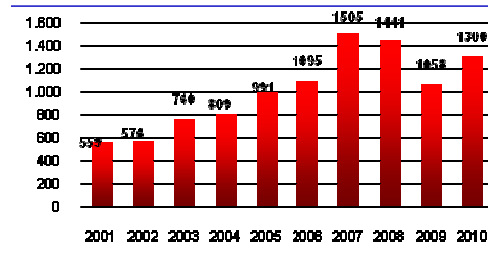

Net profit
(x €1,000,000)

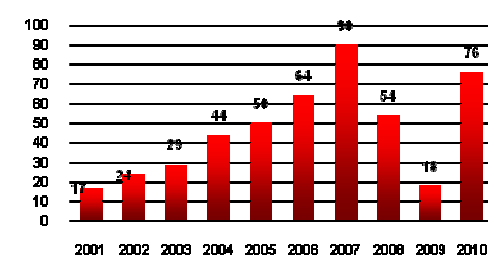

Number of employees
as of 31 December

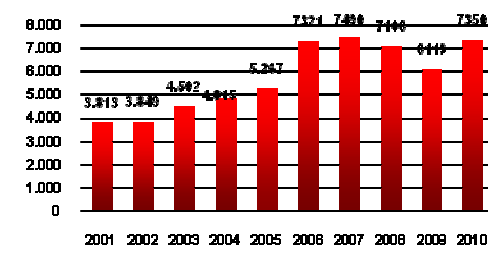

Strategy VDL Groep

- Controlled growth
 - Organisation
 - Financial position
- Improvement of competitive position
- Highest quality level
- Production:
 - The Netherlands and Flemish-speaking Belgium
 - Strategic production in low-wage countries
- Market: the whole world
- The VDL Groep is and will remain a family business company
- Priority to ensure internal career possibilities for employees



VDL Enabling Technologies Group



6 SITES



2000 SPECIALISTS



115.000 SQ.FT



400 MILLION EURO

ISO 9001, ISO 14001,

ISO 13485

ERP – BaaN IV



VDL Enabling Technologies Sales & Support Offices



-  SAN JOSE
-  BOSTON
-  EINDHOVEN & ALMELO
-  TEL AVIV
-  SINGAPORE
-  SUZHOU
-  TOKYO

VDL ETG Production plants

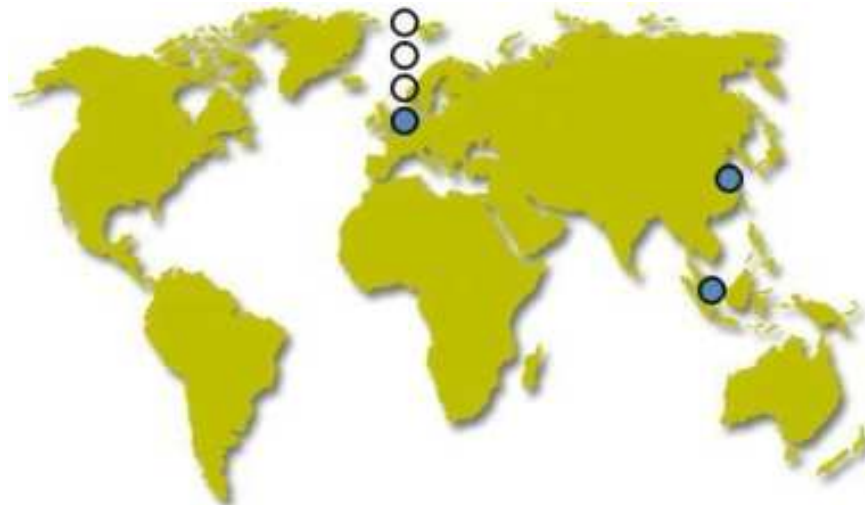

-  EINDHOVEN
-  Eindhoven
-  Projects
-  Research
-  ALMELO
-  SINGAPORE
-  SUZHOU



EINDHOVEN



750



6500 sqm



SYSTEMS
PARTS



PROJECTS



CAMPUS
TECHNOLOGY
CENTER

-  ULTRA-PRECISION TECHNOLOGY
-  VACUUM TECHNOLOGY
-  ADVANCED MATERIALS TECHNOLOGY
-  HIGH-SPEED MACHINING TECHNOLOGY
-  CLEAN ROOM ASSEMBLY
-  HIGH PRECISION SHEET METAL, INCL. JOINING
-  MULTI-AXIS COMPLEX GEOMETRY MACHINING
-  METROLOGY AND ENGINEERING SUPPORT











ALMELO



350



32.290 SQ. FT

-  VACUUM TECHNOLOGY
-  ADVANCED MATERIALS TECHNOLOGY
-  HIGH-SPEED MACHINING TECHNOLOGY
-  CLEAN ROOM ASSEMBLY
-  HIGH PRECISION SHEET METAL, INCL. JOINING
-  MULTI-AXIS COMPLEX GEOMETRY MACHINING
-  METROLOGY AND ENGINEERING SUPPORT





SINGAPORE



200



10.750 SQ.FT

- ✓ ULTRA-PRECISION TECHNOLOGY
- ✓ VACUUM TECHNOLOGY
- ✓ ADVANCED MATERIALS TECHNOLOGY
- ✓ HIGH-SPEED MACHINING TECHNOLOGY
- ✓ CLEAN ROOM ASSEMBLY
- ✓ HIGH PRECISION SHEET METAL, INCL. JOINING
- ✓ MULTI-AXIS COMPLEX GEOMETRY MACHINING
- ✓ METROLOGY AND ENGINEERING SUPPORT









SUZHOU



300



1.238 SQ.FT

-  WAFER FAB EQUIPMENT
-  LCD EQUIPMENT
-  PROFESSIONAL INDUSTRIAL EQUIPMENT
-  MULTI-AXIS COMPLEX GEOMETRY MACHINING
-  HIGH PRECISION SHEET METAL





Mission

To reach global leadership
As tier one contract manufacturing partner

By outperforming
In delivering mechatronic solutions.

Our key competences



Machining

- Modern turning and milling centers
- Multi-axis complex geometry machining
- Advanced materials technology
- Vacuum technology
- Ultra precision technology



Sheet metal

- Modern sheet metal centers
- Complex frame production
- Vacuum and specific welding methods
- Production of covering including painting
- Advanced materials technology



System integration and assembly

- Cleanroom and non cleanroom assembly
- Assembly of modules and complete systems
- Final test of complete systems and modules
- Process control and validation

Our key competences



Engineering

- (Co-) Development and engineering
- Project management (Six Sigma, Prince 2)
- Design and product optimization (DFX)
- Sustaining of product documentation
- Access to Philips resources and Technical Campus
- Long-standing relationships with knowledge institutes

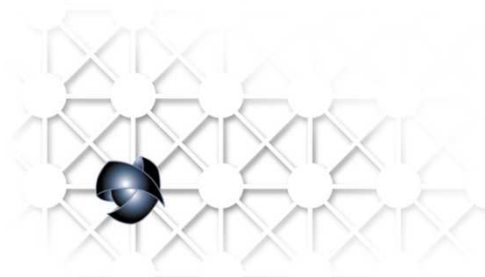

Supply-chain management

- Supply chain control and optimization
- Flexibility (see next slide)
- Lead-time road-mapping and lead time reduction
- Break-even point reduction



Property right

- Intellectual property right protection
- Production under license

ETG Value Proposition

Break Even point reduction

- Volume flexibility
- Cycle time management
- Business excellence

Life Cycle management

- Design engineering
- Feasibility and prototyping
- Cost down road-mapping
- Sustaining development

- (Value) engineering support
- Reduction of management time spent on manufacturing
- Reduction of overhead to manage supply chain
- Benefit from first in class supply chain and manufacturing capabilities
- Get rid of costs and 'headaches' related to ramp up and down
- Working capital reduction
- Support from prototyping to volume production to end of life management
- Technology partnership
- Global footprint

Core Competences

Vacuum

Positionering

Handling

Chambers

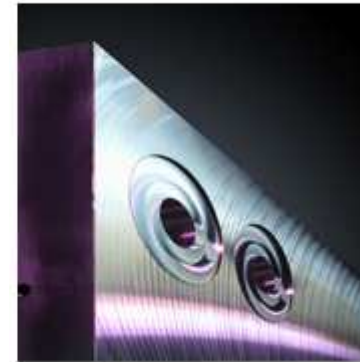

System assembly I

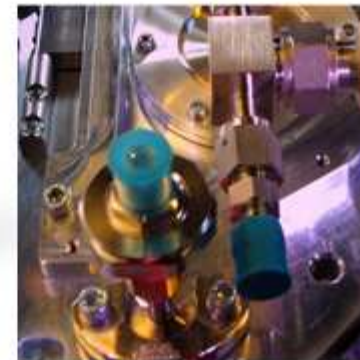
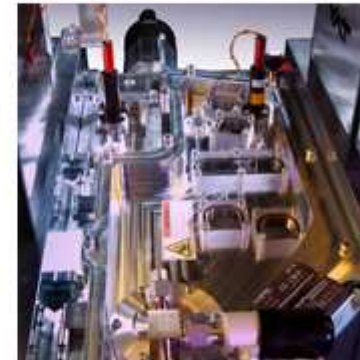



ETG in Solar

2 verschillende technologieën

Crystalline

Dunne film

Key OEM Players

Applied Materials

Baccini

PWS

Applied Films

Centrotherm - FHS

Roth & Rau – OTB

Schmidt

Von Aardenne

Oerlikon

Tempress

Smit ovens

Eurotron

Levitech

SolayTech

First Solar

Odersun



Productie equipment voor silicium zonnecellen



Wet Processes



Difusie



PECVD



Wafer cutting



Handling



Printing

Dunnefilm productie equipment



PECVD



PECVD



TCO



Laser

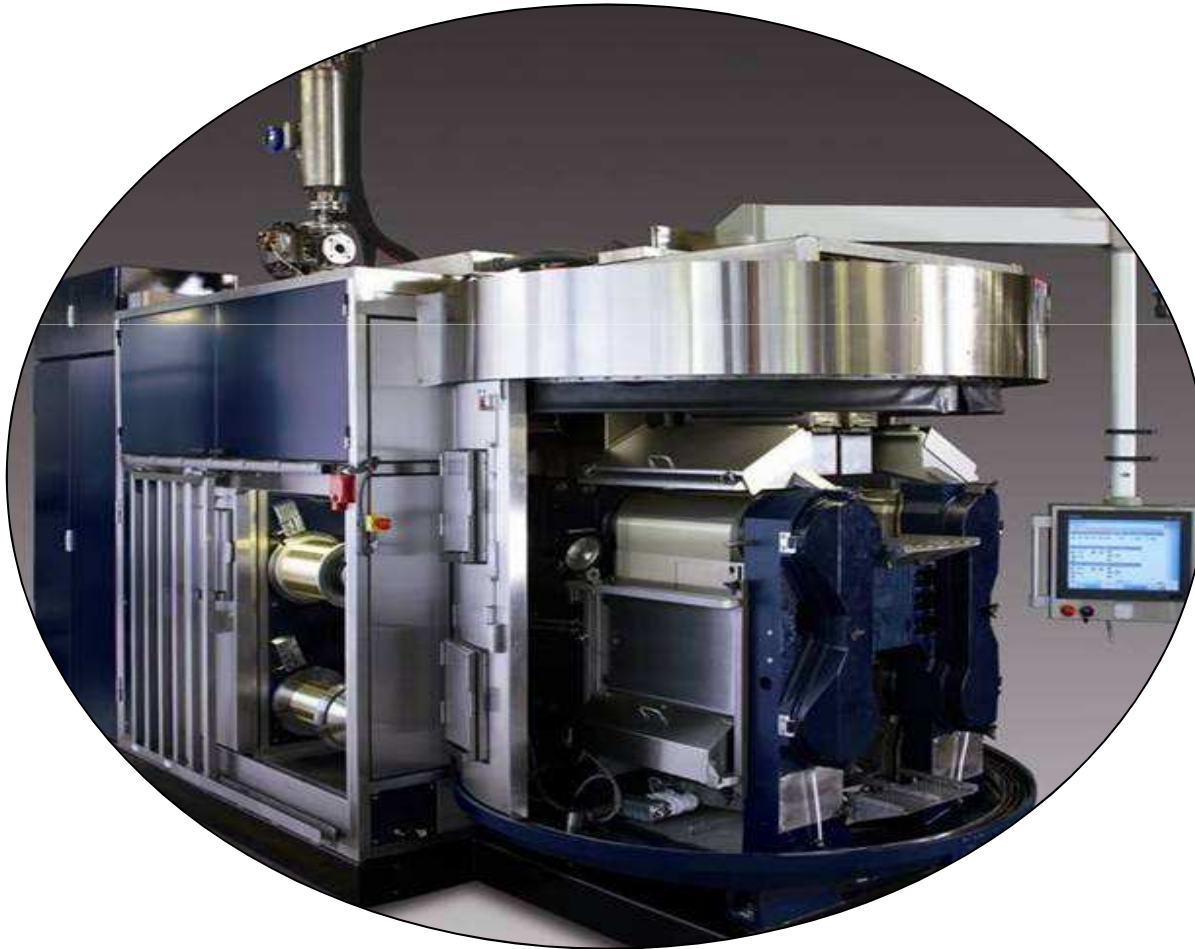

Layout

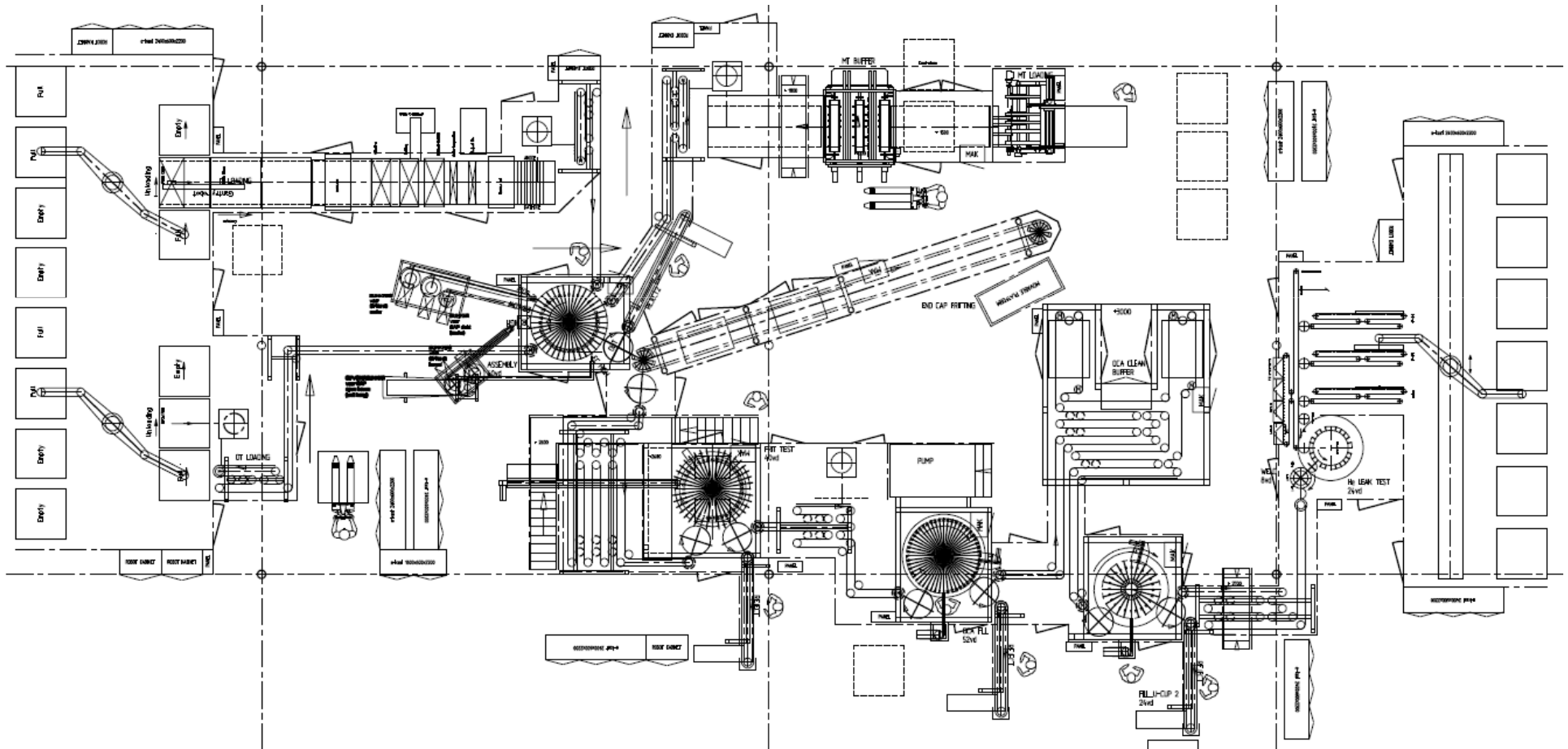



**Enabling you to achieve
your high-tech ambitions**